

- NOTES:
- MATERIAL:
 - MOLDING: LCP UL94 V-0
 - CONTACT: COPPER ALLOY.
 - PLATED GOLD ON CONTACT AREA, G/F GOLD ON SOLDER AREA, 50u" NICKEL PLATING OVER ALL.
 - MECHANICAL:
 - SHELL: SUS304-H,T=0.30±0.03mm
 - 50u" NICKEL PLATING OVER ALL.
 - EMI SHILD: SUS304-H,T=0.12±0.03mm
 - LATCH: SUS301-H,T=0.15±0.03mm
 - ELECTRICAL:
 - INSERTION: 5~20N.
 - EXTRACTION: 8~20N.
 - DURABILITY: 10000 CYCLES
 - ENVIRONMENTAL:
 - CURRENT: 5A MAX FOR VBUS; 1.25A MAX FOR OTHER.
 - VOLTAGE: 20VDC MAX
 - WITHSTANDING VOLTAGE: 100V AC.
 - CONTACT RESISTANCE: 40mΩ MAX.
 - INSULATION RESISTANCE: 100MΩ MIN.
 - TEMPERATURE RANGE: -30°C TO +80°C

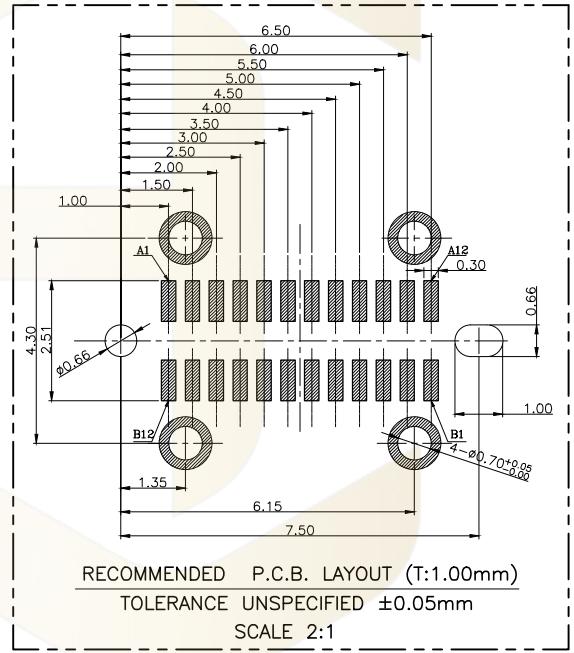

USB TYPE-C PIN ASSIGNMENTS			
PIN NUMBER	SIGNAL NAME	PIN NUMBER	SIGNAL NAME
A1	GND	B12	GND
A2	SSTXP1	B11	SSRX1
A3	SSTXN1	B10	SSRXN1
A4	VBUS	B9	VBUS
A5	CC1	B8	SBU2
A6	Dp1	B7	Dn2
A7	Dn1	B6	Dp2
A8	SBU1	B5	CC2
A9	VBUS	B4	VBUS
A10	SSRXN2	B3	SSTXN2
A11	SSRXP2	B2	SSTXP2
A12	GND	B1	GND

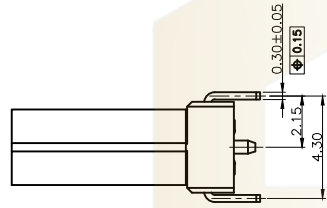
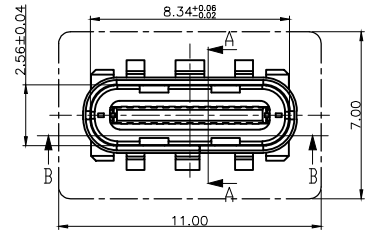
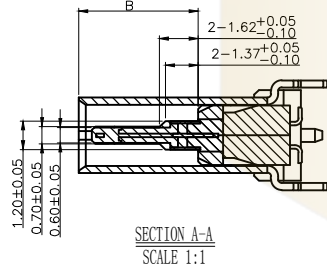
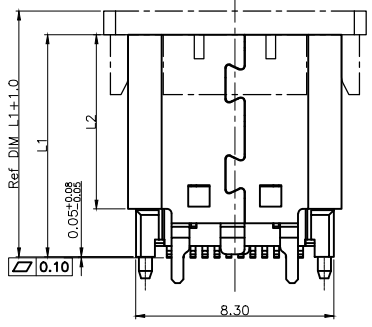

RECOMMENDED P.C.B. LAYOUT (T:1.00mm)
TOLERANCE UNSPECIFIED ±0.05mm
SCALE 2:1

P/N	L1	L2	B	F脚长	COLOR	额定电流
HC-TYPE-C-24P-VS10, 5-5A-F1, 1-04	10, 50mm	8, 55mm	6, 20mm	1, 10mm	黑色	5A
HC-TYPE-C-24P-VS9, 3-5A-F1, 1-04	9, 30mm	7, 35mm	5, 00mm	1, 10mm	黑色	5A
HC-TYPE-C-24P-VS8, 8-5A-F1, 1-04	8, 80mm	6, 80mm	4, 50mm	1, 10mm	黑色	5A

Ordering Information

HC-TYPE-C - 24P - ** - *A - F* - * - 04

Pin #	Type	Mount	Current	Foot Length	Colour
4P	1x4-Top	Mount (0.8)	3A	1.10mm	Black
5P	DS-DP+SM	Mount (0.8)	3A	1.10mm	White
6P	Mini-Mid	Mount (0.8)	5A	1.10mm	Blue
12P	CS-Center	Height (0.8)			Green
16P	VS-Vertical	SM (0.8, 1.0)			Orange
24P	DP-DP	Mount (0.8)			Purple
	FL-Flag	Mount (0.8)			Yellow

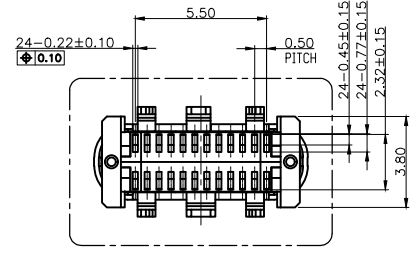

1	初版发行	日期	GENERAL TOLERANCE		制图	
			DIM	TOL	DRAWING	CHECK
序号	变更内容	日期	X.X	±0.30	审核	投影
			X.XX	±0.20	批准	
			X.XXX	±0.10	比例	
No.	变更内容	日期	Angle	±3.0°	SCALE	投影

深圳市华灿天禄电子有限公司
ShenzhenhuacantianluELECTRONICS CO., LTD

产品名称	版本	材料
TYPE CF 24P 直立式	A	
L10, 50/9, 30/8, 80mm 无弹带柱 脚1.1	REV.	
产品料号	单位	页次
HC-TYPE-C-24P-VSX-5A-F1, 1-04	UNITS	SHEET
	mm	1/2

pcs/box	boxes/Carton	Pcs/Box
450	12	5400

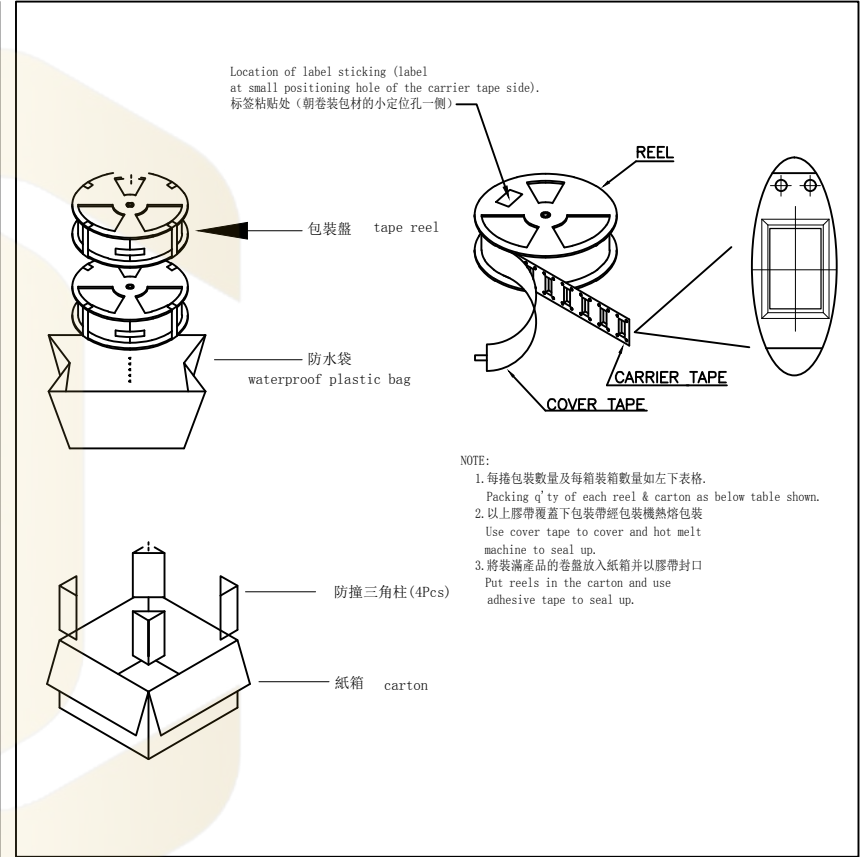
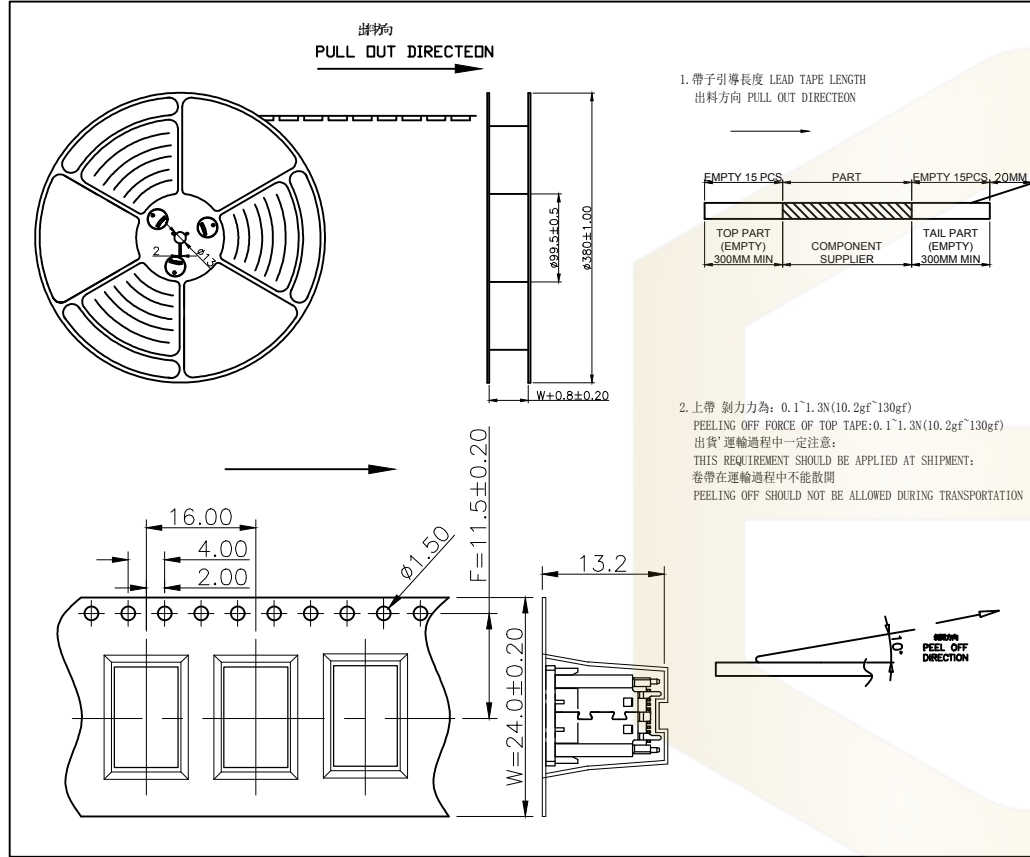

			GENREL TOLERANCE		制 圖 DRAWING		深圳市华灿天禄电子有限公司 ShenzhenhuacantianluELECTRONICS CO., LTD			
			DIM	TOL	审 核 CHECK					
			X.X	±0.30	批 准 APPROVAL		产品名称 TITLE	TYPE CF 24P 直立式 L10.50/9.30/8.80mm 无弹带柱 脚1.1-包装图	版本 REV.	A
			X.XX	±0.20	比 例 SCALE		产品料号 PART NO.	HC-TYPE-C-24P-VSX-5A-F1.1-04	单 位 UNITS	mm
			X.XXX	±0.10	投 影 Projection		材 料 MATERIAL		页 次 SHEET	2/2
序号 No.	变更内容 MODIFY CONTENT	日期 MODIFY DATE	Angle	±3.0°						